

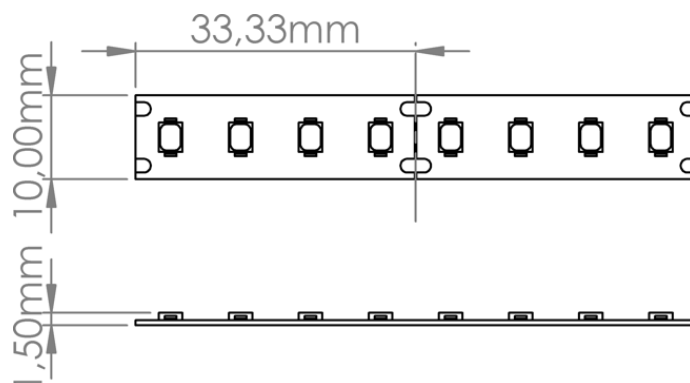

LR5293 IP20 48V

Ruban LED monochrome grande longueur



Caractéristiques techniques

LARGEUR	10,0mm
PUISSANCE MAXIMALE	10,0W/m
POIDS	18g/m, 23g/m
LONGUEUR MAX DU PRODUIT ALIMENTÉ D'UN CÔTÉ	30,0m
SÉCABILITÉ	3,33cm
HAUTEUR	0,15 cm
CONDITIONNEMENT	1



Références

NOM COMMERCIAL RÉF. CONSTRUCTEUR	LONGUEUR	TEINTE	FLUX	EFFICACITÉ LUMINEUSE	CLASSE ÉNERGÉTIQUE
LR5293-IP20-48-30BL27 ENG0100300000001	30m	2700 °K	1020lm/m	102lm/W	F
LR5293-IP20-48-30BL30 ENG0100300000002	30m	3000 °K	1040lm/m	104lm/W	F
LR5293-IP20-48-30BL40 ENG0100300000003	30m	4000 °K	1100lm/m	110lm/W	F
LR5293-IP20-48-30BL60 ENG0100300000004	30m	6000 °K	1030lm/m	103lm/W	F
LR5293-IP20-48SPBL27 ENG0110300000001	1,0cm	2700 °K	1020lm/m	102lm/W	F
LR5293-IP20-48SPBL30 ENG0110300000002	1,0cm	3000 °K	1040lm/m	104lm/W	F
LR5293-IP20-48SPBL40 ENG0110300000003	1,0cm	4000 °K	1100lm/m	110lm/W	F
LR5293-IP20-48SPBL60 ENG0110300000004	1,0cm	6000 °K	1030lm/m	103lm/W	F

Accessoires associés non inclus

NOM COMMERCIAL RÉF. CONSTRUCTEUR	DESCRIPTION	COULEUR	MATIERE	ILLUSTRATION
LAL-HLG-320H-48 ENG0500300000006	HLG-320H-48 ALIMENTATION NON DIMMABLE IP67 D'UNE PUISSANCE DE 320W AVEC UNE TENSION DE SORTIE DE 48V			